

IT/EN

SERIE
C1D/XE Cilindri ISO15552 ø32-125
ISO15552 cylinders ø32-125

Cilindro ISO15552 ø32-125 - Serie C1D/XE
ISO15552 cylinders ø32-125 - C1D/XE series

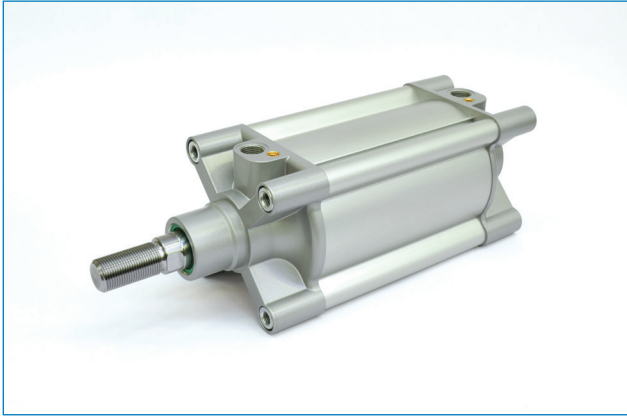

Materiali - Materials	
Testate.....	Alluminio pressofuso verniciato
Covers.....	Painted die-casted aluminium
Tubo.....	Alluminio anodizzato
Tube.....	Anodized aluminium
Pistone.....	NBR + acciaio
Piston.....	NBR + steel
Guarnizioni.....	PU / NBR
Seals.....	
Boccola guida.....	Bronzo sinterizzato
Guiding bush.....	Sintered bronze
Stelo.....	Acciaio cromato
Piston rod.....	Chromium coated steel

Caratteristiche tecniche - Technical features	
Fluido.....	Aria compressa filtrata lubrificata e non
Fluid.....	Filtered and lubricated or not compressed air
Temperatura di impiego	-20°C +80°C con aria secca
Working temperature	-20°C +80°C with dry air
Pressione di utilizzo.....	
Pressure range.....	max 10 bar

Chiavi di codifica
Cylinders key code

C 1 D 0 3 2 S 0 1 2 5 F S T

Versione Version	Diametro Bore	Tipo costruttivo Design type	Corsa Stroke	Versione Version	Varianti Variants
C1D Cilindro ISO15552 ISO15552 cylinder	32	S Standard	0005	Doppio effetto non magnetico C Double acting non magnetic	Standard ST
	40		Doppio effetto magnetico D Double acting magnetic	Stelo AISI 304 XI AISI 304 rod
	50		2700	Doppio effetto con ammortizzo regolabile non magnetico E Double acting with adjustable cushioning non magnetic	Stelo AISI 316 AF AISI 316 rod
	63		Doppio effetto con ammortizzo regolabile magnetico F Double acting with adjustable cushioning magnetic	Alta temperatura VT High temperature	
	80		Doppio effetto stelo passante non magnetico L Double acting through rod non magnetic	Guarnizione stelo FKM VG FKM rod seal	
	100		Doppio effetto stelo passante magnetico M Double acting through rod magnetic	Raschiastelo duro E8 Hard scraper	
	125		Doppio effetto stelo passante con ammortizzo regolabile non magnetico N Double acting through rod with adjustable cushioning non magnetic	Guarnizione stelo per food FD Food rod seal	
			Doppio effetto stelo passante con ammortizzo regolabile magnetico P Double acting through rod with adjustable cushioning magnetic	Raschiastelo metallico EW Metal scraper	
				Certificazione ATEX EX ATEX certification	

Corse standard Standard strokes

∅	10	25	50	80	100	125	160	200	250	300	320	400	500	600	700	800	900	1000
32	•	•	•	•	•	•	•	•	•	•	•	•	•	•	•	•	•	•
40	•	•	•	•	•	•	•	•	•	•	•	•	•	•	•	•	•	•
50	•	•	•	•	•	•	•	•	•	•	•	•	•	•	•	•	•	•
63	•	•	•	•	•	•	•	•	•	•	•	•	•	•	•	•	•	•
80	•	•	•	•	•	•	•	•	•	•	•	•	•	•	•	•	•	•
100	•	•	•	•	•	•	•	•	•	•	•	•	•	•	•	•	•	•
125	•	•	•	•	•	•	•	•	•	•	•	•	•	•	•	•	•	•

Forze teoriche a 6 bar (N) Theoretical forces at 6 bar (N)

∅	Forza di spinta Thrust force	Forza di trazione Traction force
32	482	414
40	754	633
50	1178	989
63	1869	1681
80	3014	2720
100	4710	4416
125	7359	6877

Esecuzione a richiesta On request

Caratteristiche - Features

- Resistente alle basse temperature -40...+80°C - Low temperature resistant -40...+80°C
- Stelo prolungato - Piston rod extension
- Lubrificazione FDA - FDA lubrication
- Filettature e steli su richiesta - Custom made thread or piston rod
- Configurazione tandem a più posizioni - Multi position configuration
- Configurazione tandem a doppia spinta - Double thrust tandem configuration
- Configurazione tandem contrapposti anteriore - Front opposed tandem configuration
- Configurazione tandem contrapposti posteriore - Rear opposed tandem configuration

Accessori di fissaggio
Mounting accessories

Descrizione Description	Alluminio Aluminium	Acciaio Steel	Acciaio inox Stainless steel
1 Supporto per cerniera intermedia / Support for intermediate hinge (AT4)	//	SUPøS	//
2 Cerniera oscillante anteriore-posteriore / Front-rear trunnion (MT5/MT6)	//	CRBøS	//
3 Flangia / Flange (MF1/MF2)	//	AFPøS	AFPøI
4 Bloccastelo / Rod lock	BLSø	//	//
5 Forcella / Clevis	//	FORMø	FORMøI
6 Testa a snodo / Rod end	//	TSNDMø	TSNDMøI
7 Dado per aste / Piston rod nut	//	ANAø	ANAøI
8 Piedino basso / Low-rise pedestal	//	AFDøS	AFDøI
9 Unità di guida / Guide unit	NRB-NRS-NRU	//	//
10 Cerniera intermedia per tubo profilato / Intermediate hinge for profile tube (MT4)	//	CIPøS	//
11 Cerniera maschio snodata / Male hinge with spherical bearing (MP6)	CMTøA	CMTøS	CMTøI
12 Cerniera femmina stretta per snodo sferico / Clevis bracket, spherical eye, straight (AB6)	CFSøA	CFSøS	CFSøI
13 Cerniera femmina / Female hinge (MP2)	CRFøA	CRFøS	CRFøI
14 Cerniera maschio / Male hinge (MP4)	CRMøA	CRMøS	CRMøI
15 Perno per cerniera femmina / Pivot for female hinge (AA4)	//	PRCøS	PRCøI
16 Articolazione a squadra / Square joint (AB7)	ARTøA	ARTøS	ARTøI
17 Perno per cerniera snodata / Pivot pin, spherical bearing (AA6)	//	PRSøS	PRSøI
18 Articolazione a squadra con testina snodata DIN 648 K / Square joint with spherical head DIN 648 K	//	ARSøS	ARSøI
19 Giunto autoallineante / Self-aligning joint	//	GASMø	//

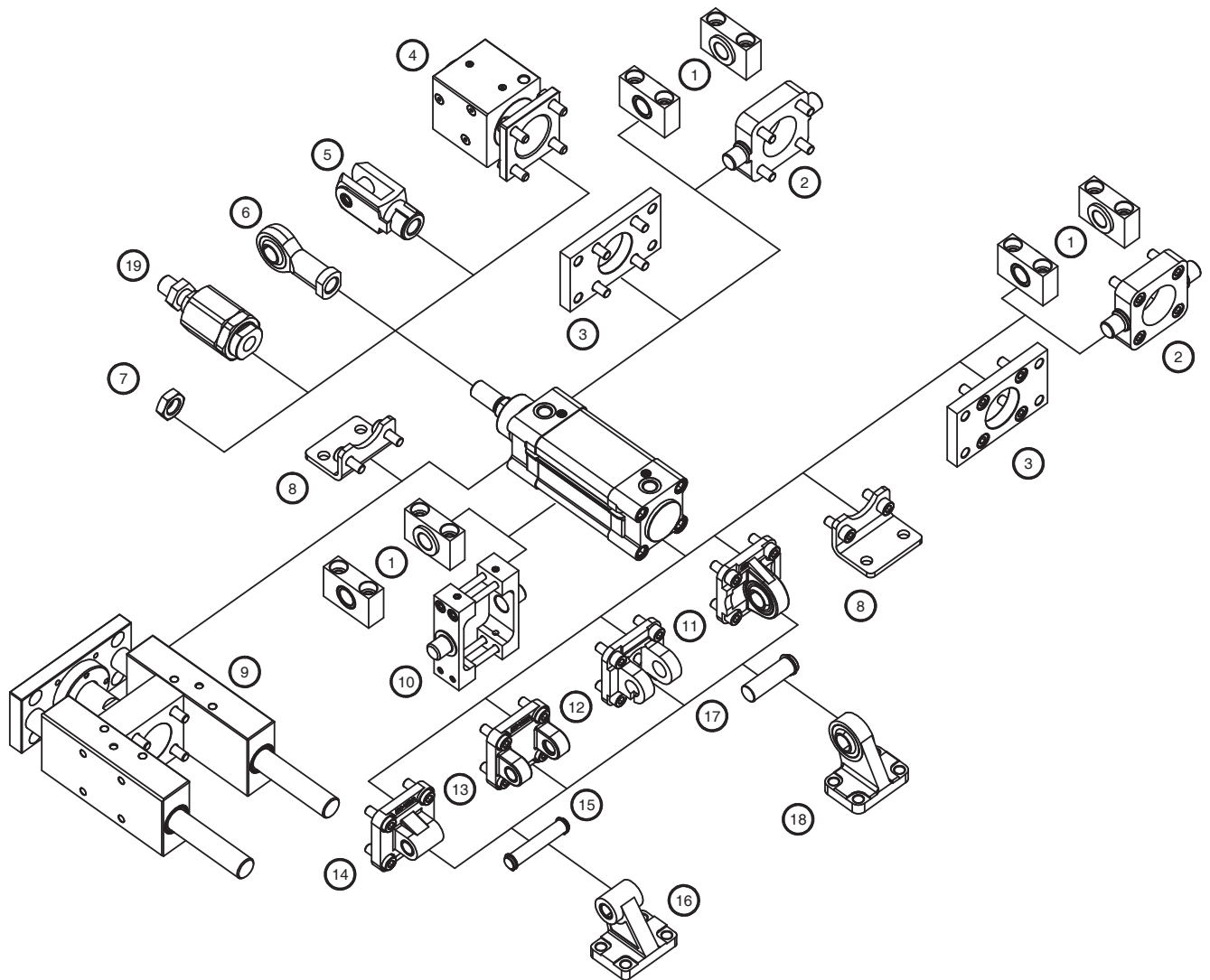

Doppio effetto
Double acting

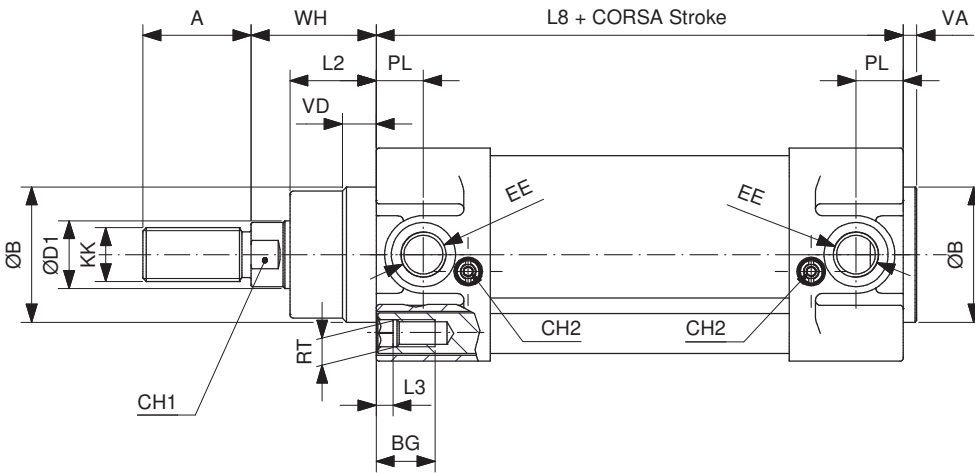

C1DøS...CST - C1DøS...DST
C1DøS...EST - C1DøS...FST

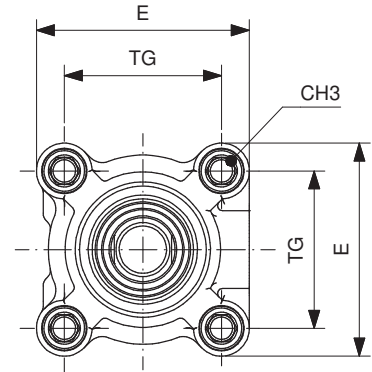

Ø	ØD1	KK	A	ØB	VD	VA	L2	RT	BG	L3	TG	EE	PL	WH	L8	E	CH1	CH2	CH3
32	12	M10X1.25	22	30	8	4	18	M6	16.5	5	32.5	1/8"G	12.5	26	94	47	10	1.5	6
40	16	M12X1.25	24	35	10	4	22	M6	16.5	5	38	1/4"G	14	30	105	54	13	1.5	6
50	20	M16X1.5	32	40	10	4	25.5	M8	17.5	5	46.5	1/4"G	14	37	106	63	17	1.5	8
63	20	M16X1.5	32	45	10	4	25	M8	17.5	5	56.5	3/8"G	18.25	37	121	74	17	1.5	8
80	25	M20X1.5	40	45	10	4	35	M10	17.5	//	72	3/8"G	18.5	46	128	93.5	22	1.5	6
100	25	M20X1.5	40	55	12	4	38	M10	17.5	//	89	1/2"G	20	51	138	110	22	1.5	6
125	32	M27X2	54	60	12	6	46	M12	20.5	//	110	1/2"G	29	65	160	137.5	27	1.5	8

Doppio effetto passante
Double acting through piston rod

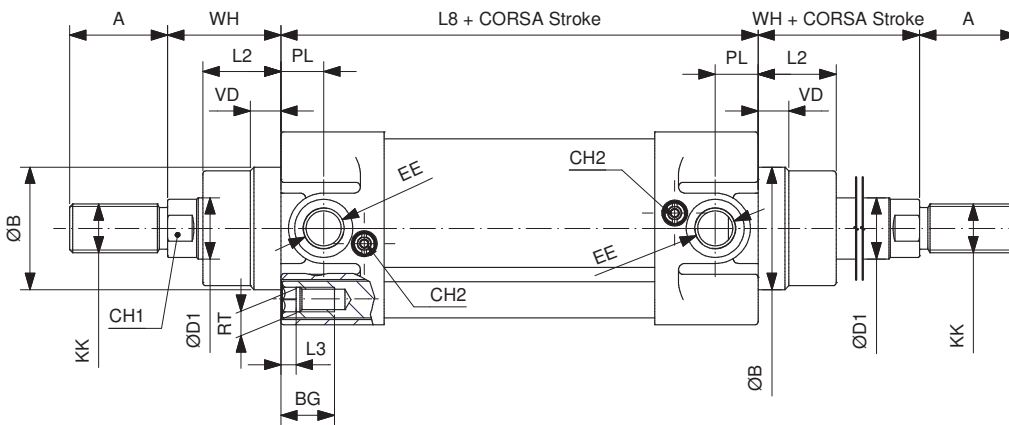
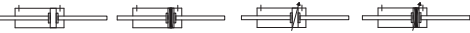

C1DøS...LST - C1DøS...MST
C1DøS...NST - C1DøS...PST

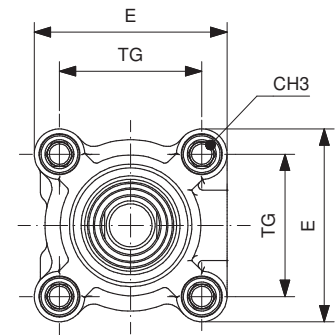

Ø	ØD1	KK	A	ØB	VD	L2	RT	BG	L3	TG	EE	PL	WH	L8	E	CH1	CH2	CH3
32	12	M10X1.25	22	30	8	18	M6	16.5	5	32.5	1/8"G	12.5	26	94	47	10	1.5	6
40	16	M12X1.25	24	35	10	22	M6	16.5	5	38	1/4"G	14	30	105	54	13	1.5	6
50	20	M16X1.5	32	40	10	25.5	M8	17.5	5	46.5	1/4"G	14	37	106	63	17	1.5	8
63	20	M16X1.5	32	45	10	25	M8	17.5	5	56.5	3/8"G	18.25	37	121	74	17	1.5	8
80	25	M20X1.5	40	45	10	35	M10	17.5	//	72	3/8"G	18.5	46	128	93.5	22	1.5	6
100	25	M20X1.5	40	55	12	38	M10	17.5	//	89	1/2"G	20	51	138	110	22	1.5	6
125	32	M27X2	54	60	12	46	M12	20.5	//	110	1/2"G	29	65	160	137.5	27	1.5	8



Via del Commercio, 13
23017 Morbegno (SO) Italia
Tel +39 0342/605011
Fax +39 0342/614971

www.cypag.com
sales@cypag.com