

# CILINDRI CNOMO Ø25-200 CNOMO CYLINDERS Ø25-200

**DOPPIO EFFETTO**  
**DOUBLE ACTING**

CACØS...CST

CACØS...DST

CACØS...EST

CACØS...FST

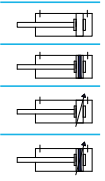
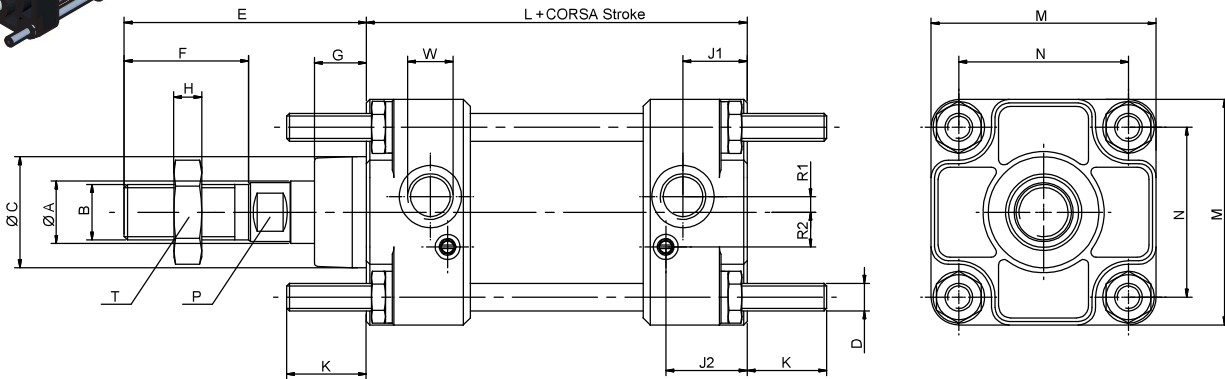
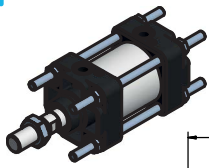

Ømm	ØA(f7)	B	ØC(e9)	E	F	G	L(±1)	P	T	H	D	K	W	M	N	J1	J2	R1	R2
25	12	M10x1.5	25	45	20	15	80	8	17	6	M6	17	1/8"	40	28	7	11	0.75	7.5
32	12	M10x1.5	25	45	20	15	80	8	17	6	M6	17	1/8"	45	33	15	16.5	6	8
40	18	M16x1.5	32	70	36	15	110	13	24	8	M6	17	1/4"	52	40	17.5	23	3	11
50	18	M16x1.5	32	70	36	15	110	13	24	8	M8	23	1/4"	65	49	18.5	23.5	4.5	10
63	22	M20x1.5	45	85	46	20	125	17	30	9	M8	23	3/8"	75	59	19	23	4.5	14
80	22	M20x1.5	45	85	46	20	125	17	30	9	M10	28	3/8"	95	75	22	25	8	13
100	30	M27x2	55	110	63	20	145	22	41	12	M10	28	1/2"	115	90	26	31	12	10
125	30	M27x2	55	110	63	20	145	22	41	12	M12	34	1/2"	140	110	-	-	-	-
160	40	M36x2	65	135	85	25	180	32	54	14	M16	42	3/4"	180	140	-	-	-	-
200	40	M36x2	65	135	85	25	180	32	54	14	M16	42	3/4"	220	175	-	-	-	-

**DOPPIO EFFETTO PASSANTE**  
**DOUBLE ACTING THROUGH PISTON ROD**

CACØS...LST

CACØS...MST

CACØS...NST

CACØS...PST

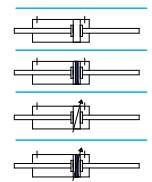
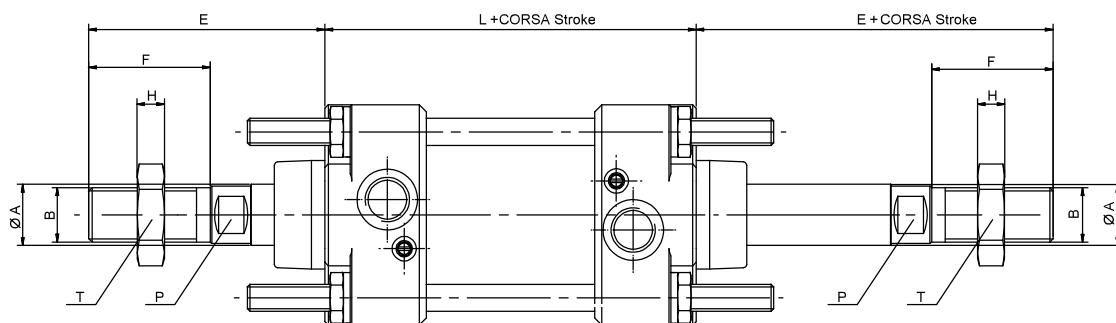
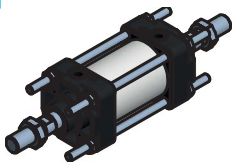

Ømm	ØA(f7)	B	E	F	L(±1)	P	T	H
25	12	M10x1.5	45	20	90	8	17	6
32	12	M10x1.5	45	20	90	8	17	6
40	18	M16x1.5	70	36	129	13	24	8
50	18	M16x1.5	70	36	129	13	24	8
63	22	M20x1.5	85	46	143	17	30	9
80	22	M20x1.5	85	46	143	17	30	9
100	30	M27x2	110	63	164	22	41	12
125	30	M27x2	110	63	164	22	41	12
160	40	M36x2	135	85	200	32	54	14
200	40	M36x2	135	85	200	32	54	14

## ACCESSORI DI FISSAGGIO MOUNTING ACCESSORIES

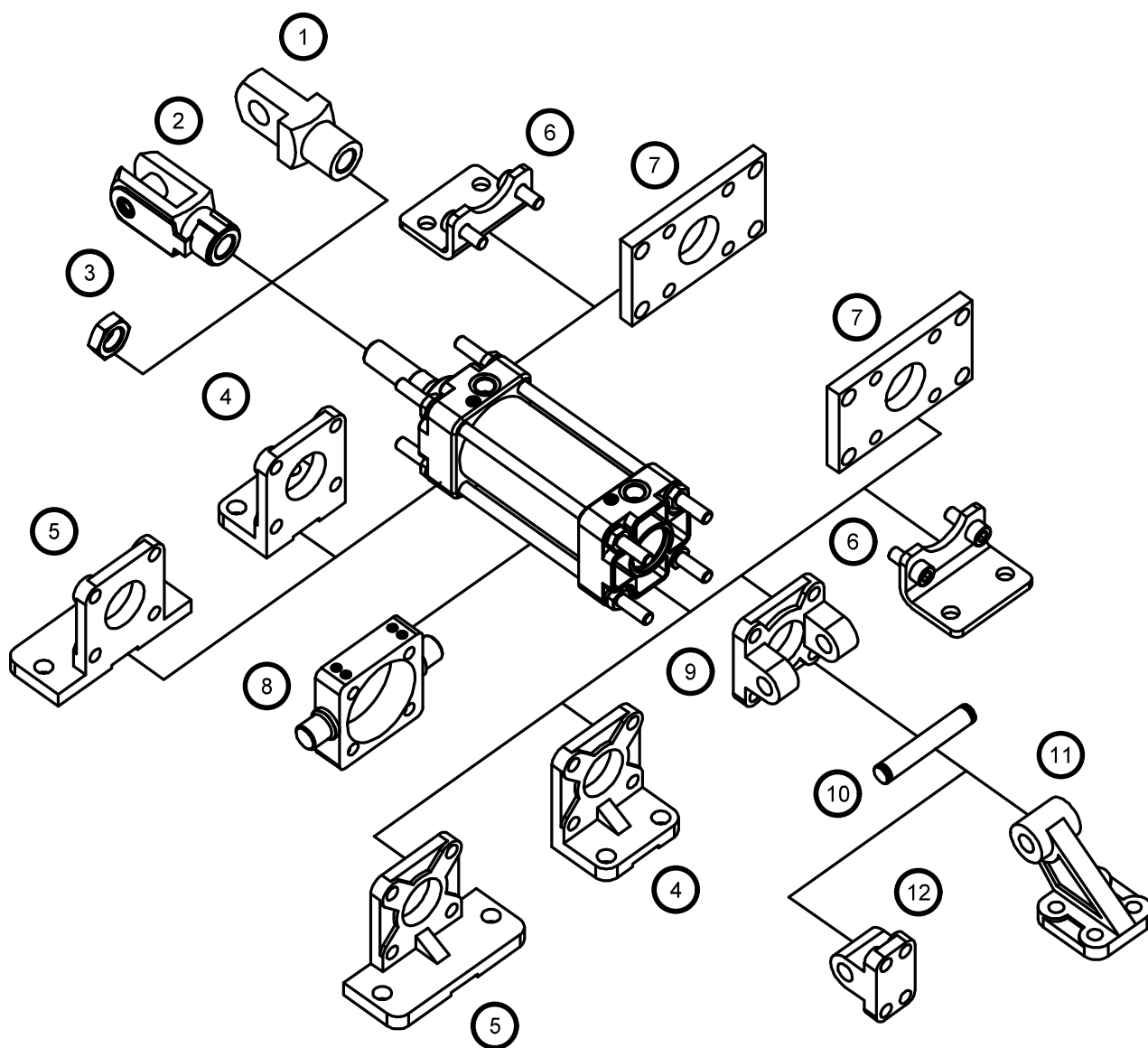

Descrizione Description	Alluminio Aluminium	Acciaio Steel
1 Forcella maschio / Male clevis	-	8
2 Forcella femmina / Female clevis	-	7
3 Dado per aste / Piston rod nut	-	130
4 Piedino alto / High pedestal	6	-
5 Piedino alto largo / High large pedestal	7	-
6 Piedino basso / Low rise pedestal	-	9
7 Flangia lamata / Spot faced flange	-	8
8 Cerniera intermedia rotonda / Intermediate adjustable hinge	-	10
9 Cerniera femmina / Female hinge	5	-
10 Perno per cerniera femmina / Pivot for female hinge	-	9
11 Articolazione a squadra / Square joint	6	-
12 Articolazione normale / Rear clevis bracket	5	-

# ACCESSORI DI FISSAGGIO MOUNTING ACCESSORIES

## CERNIERA FEMMINA FEMALE HINGE

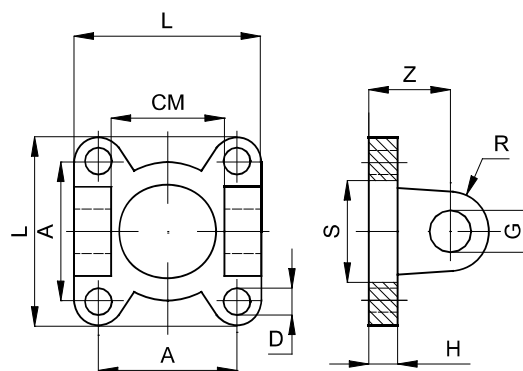

Materiale Alluminio  
Material Aluminium

CODICE/CODE	A	L	D	H	CM	S	R	Z	G
CFC32A	33	45	7	8	26	25	8	18	8
CFC40A	40	52	7	8	33	32	12	24	12
CFC50A	49	65	9	10	33	32	12	26	12
CFC63A	59	75	9	10	47	45	16	30	16
CFC80A	75	95	11	12	47	45	16	32	16
CFC100A	90	115	11	12	57	55	20	37	20
CFC125A	110	140	14	16	57	55	21	41	20
CFC160A	140	180	18	20	72	65	25	55	25
CFC200A	175	220	18	20	72	65	25	55	25

## ARTICOLAZIONE NORMALE REAR CLEVIS BRACKET

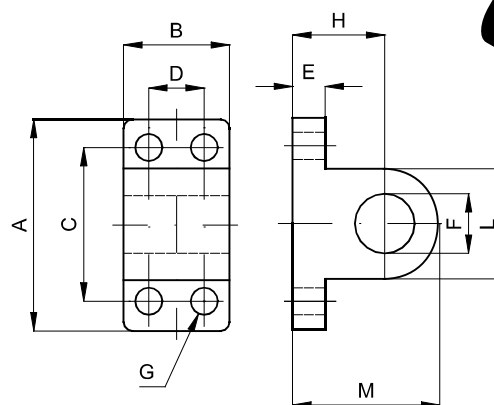

Materiale Alluminio  
Material Aluminium

CODICE/CODE	A	B	C	D	E	F	G	H	L	M
ACN32A	40	25	28	-	8	8	7	18	16	26
ACN4050A	52	32	38	16	10	12	9	26	24	38
ACN6380A	75	46	54	25	12	16	11	34	36	52
ACN100125A	115	56	90	32	16	20	14	41	40	61
ACN160200A	180	71	150	43	20	25	18	55	50	80

## ARTICOLAZIONE A QUADRA SQUARE JOINT

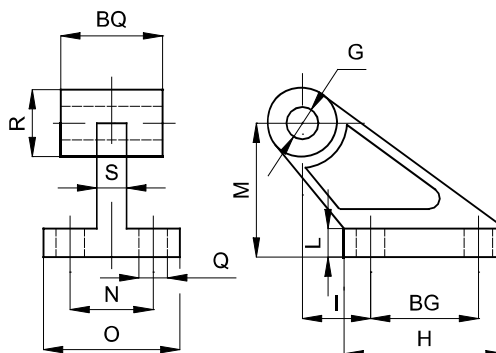

Materiale Alluminio  
Material Aluminium

CODICE/CODE	Q	BG	H	I	L	M	N	O	S	R	BQ	G
ARC32A	7	20	37	18	8	32	25	41	9	19,5	25	8
ARC4050A	9	32	54	25	10	45	32	52	14	26	32	12
ARC6380A	11	50	75	32	13	63	40	63	14	32	46	16
ARC100125A	14	70	103	40	17	90	50	80	22	42	56	20
ARC160200A	18	110	154	50	20	140	63	111	26	54	70	25

## PIEDINO ALTO HIGH PEDESTAL

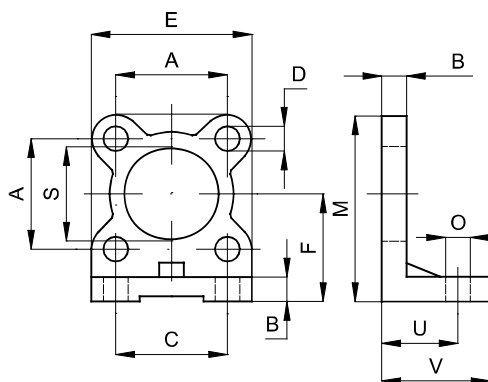

Materiale Alluminio  
Material Aluminium

CODICE/CODE	A	B	C	D	E	F	M	O	S	U	V
PAC32A	33	8	28	7	45	32	54	9	25	27	35
PAC40A	40	8	36	7	52	36	62	9	32	27	35
PAC50A	49	10	45	9	65	45	77	11	32	35	45
PAC63A	59	10	55	9	75	50	87	11	45	35	45
PAC80A	75	12	70	11	95	63	110	14	45	43	55
PAC100A	90	12	90	11	115	73	130	14	55	43	55
PAC125A	110	16	110	14	140	91	161	18	55	52	68
PAC160A	140	20	130	18	180	115	205	22	65	62	82
PAC200A	175	20	170	18	220	135	245	22	65	62	92

# ACCESSORI DI FISSAGGIO MOUNTING ACCESSORIES

## PIEDINO ALTO LARGO HIGH LARGE PEDESTAL

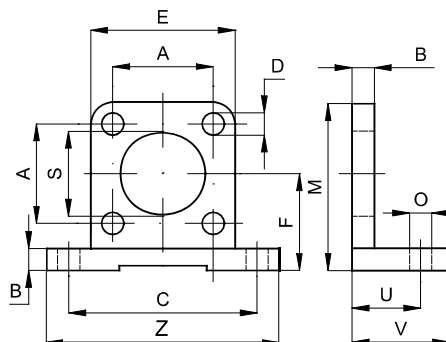

Materiale Alluminio  
Material Aluminium

CODICE/CODE	A	B	C	D	E	F	M	O	S	U	V	Z
PLC32A	33	8	65	7	46	32	54	9	25	18	35	82
PLC40A	40	8	72	7	52	36	62	9	32	18	35	90
PLC50A	49	10	90	9	65	45	77	11	32	22	45	110
PLC63A	59	10	100	9	75	50	87	11	45	22	45	120
PLC80A	75	12	126	11	95	63	110	14	45	28	55	154
PLC100A	90	12	148	11	115	73	130	14	55	28	55	180
PLC125A	110	16	180	14	140	91	161	18	55	32	67,5	215
PLC160A	140	20	230	18	180	115	206	22	65	40	80	275
PLC200A	175	20	270	18	220	135	246	22	65	40	80	318

## FORCELLA FEMMINA FEMALE CLEVIS

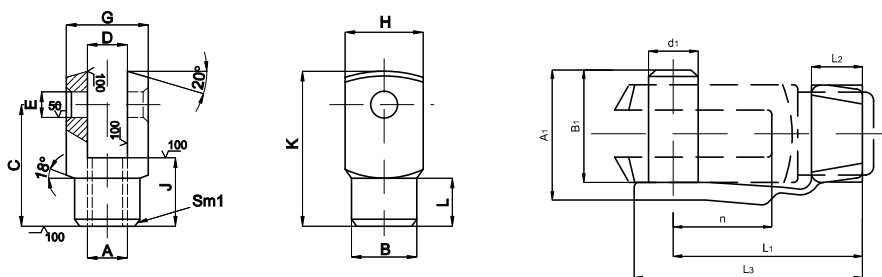

Materiale Acciaio zincato  
Material Zinc coated steel

CODICE/CODE	A	A <sub>1</sub>	B	B <sub>1</sub>	C	D <sub>H11</sub>	E <sub>H18</sub>	G	H	L <sub>1</sub>	J	L <sub>2</sub>	K	L <sub>3</sub>	L	n
FORF10CN	M10x1,5	28	18	25	36	11	8	22	22	36	20	10	45	41	14	16
FORF16CN	M16x1,5	44	26	40	51	18	12	36	26	50	26	12	64	60	17	25
FORF20CN	M20x1,5	53	34	49	63	22	16	45	34	63	30	15	80	74	18,5	33
FORF27CN	M27x2	73	42	69	85	30	20	63	42	81	45	19	105	98	30	40
FORF36CN	M36x2	-	50	-	115	40	25	80	50	-	75	-	140	-	45	-

## FORCELLA MASCHIO MALE CLEVIS

CNOMO

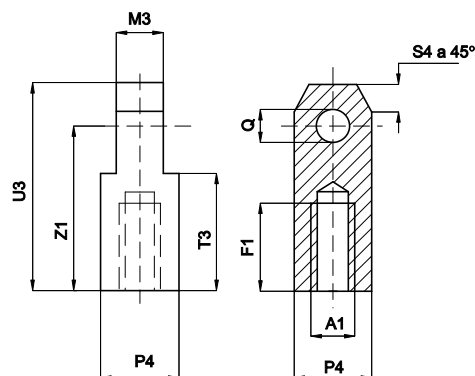

**Materiale** Acciaio zincato  
**Material** Zinc coated steel

CODICE/CODE	A <sub>1</sub>	F <sub>1</sub>	M <sub>3</sub>	P <sub>4</sub>	Q <sub>h8</sub>	S <sub>4</sub>	T <sub>3</sub>	U <sub>3</sub>	Z <sub>1</sub>
FORM10CN	M10x1,5	20	11	22	8	6	25	45	36
FORM16CN	M16x1,5	30	18	32	12	10	34	64	51
FORM20CN	M20x1,5	36	22	36	16	12	41	80	63
FORM27CN	M27x2	50	30	45	20	17,5	58	105	85
FORM36CN	M36x2	70	40	63	25	20	81	140	115

## FLANGIA LAMATA SPOT FACED FLANGE

CNOMO

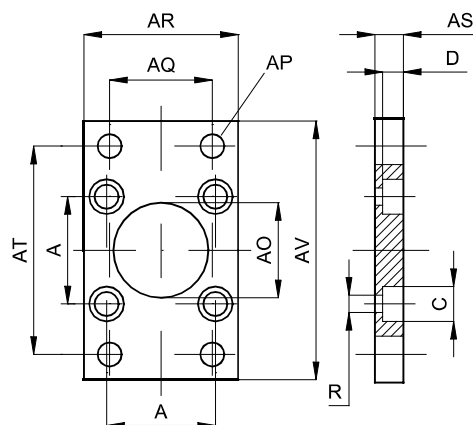

**Materiale** Acciaio zincato  
**Material** Zinc coated steel

CODICE/CODE	A	AP	AO	R	AS	AR	AQ	AT	AV	C	D
FLC32S	33	9	25	6,5	8	45	33	69	80	10,5	6
FLC40S	40	9	32	6,5	8	52	40	78	90	10,5	6
FLC50S	49	11	32	9	10	65	49	94	110	13,5	8
FLC63S	59	11	45	9	10	75	59	104	120	13,5	8
FLC80S	75	14	45	10,5	12	95	75	130	150	16,5	10
FLC100S	90	14	55	10,5	12	115	90	150	170	16,5	10
FLC125S	110	18	55	13,5	16	140	110	180	205	19	12,5
FLC160S	140	22	65	16,5	20	180	140	228	260	24,5	16,5
FLC200S	175	22	65	16,5	20	220	175	268	300	24,5	16,5

## ACCESSORI DI FISSAGGIO MOUNTING ACCESSORIES

### PIEDINO BASSO LOW RISE PEDESTAL

**GNOMO**

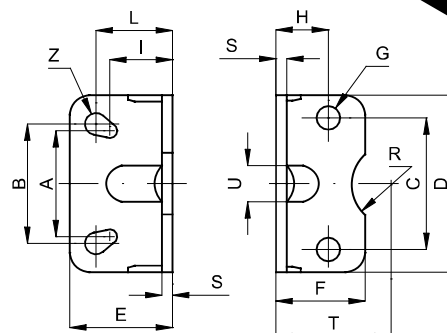

**Materiale** Acciaio zincato  
**Material** Zinc coated steel

CODICE/CODE	A	B	C	D	E	F	G	H	I	L	M	N	R	S	T	U
PBC32S	28	32	33	45	35	30	7	15,5	22	27	4,5	3,5	12,5	4	32	11
PBC40S	36	36	40	52	36	30	7	16	26	27	4,5	4,5	16	4	36	15
PBC50S	45	45	49	65	45	36	9	20,5	30	35	5,5	4,5	16	5	45	16
PBC63S	55	50	59	75	45	35	9	20,5	30	35	5,5	4,5	22,5	5	50	18
PBC80S	70	63	75	95	55	45	11	25,5	37	43	7	5,5	22,5	6	63	17
PBC100S	90	75	90	115	56	44	11	27	37,5	43	7	6,5	27,5	6	73	24
PBC125S	100	-	110	140	70	70	14	36	-	52	9	-	27,5	8	91	-
PBC160S	130	-	140	180	75	100	18	45	-	62	11	-	32,5	10	115	-
PBC200S	170	-	175	220	100	100	18	47	-	62	11	-	32,5	12	135	-

### PERNO PER CERNIERA FEMMINA PIVOT FOR FEMALE HINGE

**GNOMO**

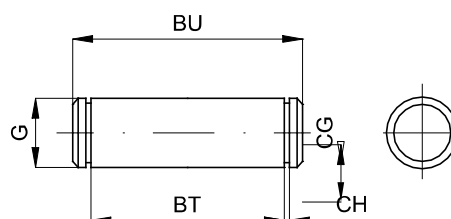

**Materiale** Acciaio zincato  
**Material** Zinc coated steel

CODICE/CODE	G	BT	CG	CH	BU
PPC32S	8	46	7,6	1,1	53
PPC40S	12	53	11,5	1,1	60
PPC50S	12	66	11,5	1,1	73
PPC63S	16	76	15,2	1,1	83
PPC80S	16	96	15,2	1,1	103
PPC100S	20	117	19	1,3	124
PPC125S	20	142	19	1,3	149
PPC160S	25	182	23,9	1,3	189
PPC200S	25	222	23,9	1,3	229

Nota: fornito completo di seeger. Note: supplied with retaining rings.

**CERNIERA INTERMEDIA ROTONDA**  
**INTERMEDIATE ADJUSTABLE HINGE**

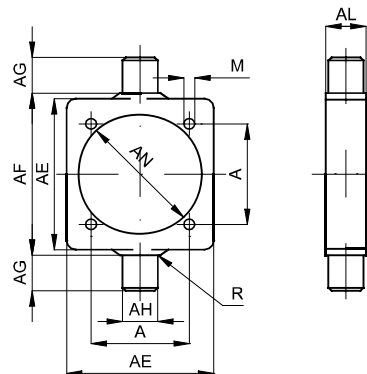

**Materiale** Acciaio zincato  
**Material** Zinc coated steel

CODICE/CODE	A	AE	AL	AH	AG	AF	AN	R	M
CIC32S	33	46	15	12	12	50	37	1	M6
CIC40S	40	59	20	16	16	63	46	1,5	M6
CIC50S	49	69	20	16	16	73	56	1,6	M8
CIC63S	59	84	25	20	20	90	69	1,6	M8
CIC80S	75	102	25	20	20	108	87	1,6	M10
CIC100S	90	125	30	25	25	131	107	2	M10
CIC125S	110	155	32	25	25	160	133,5	2	M12
CIC160S	140	190	40	32	32	200	171	2,5	M16
CIC200S	175	240	40	32	32	250	211	2,5	M16